

Heat shrink boots are used to seal Tracepak tubing bundles entering the enclosure.

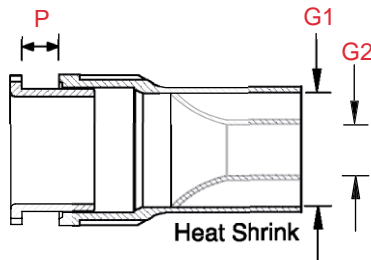
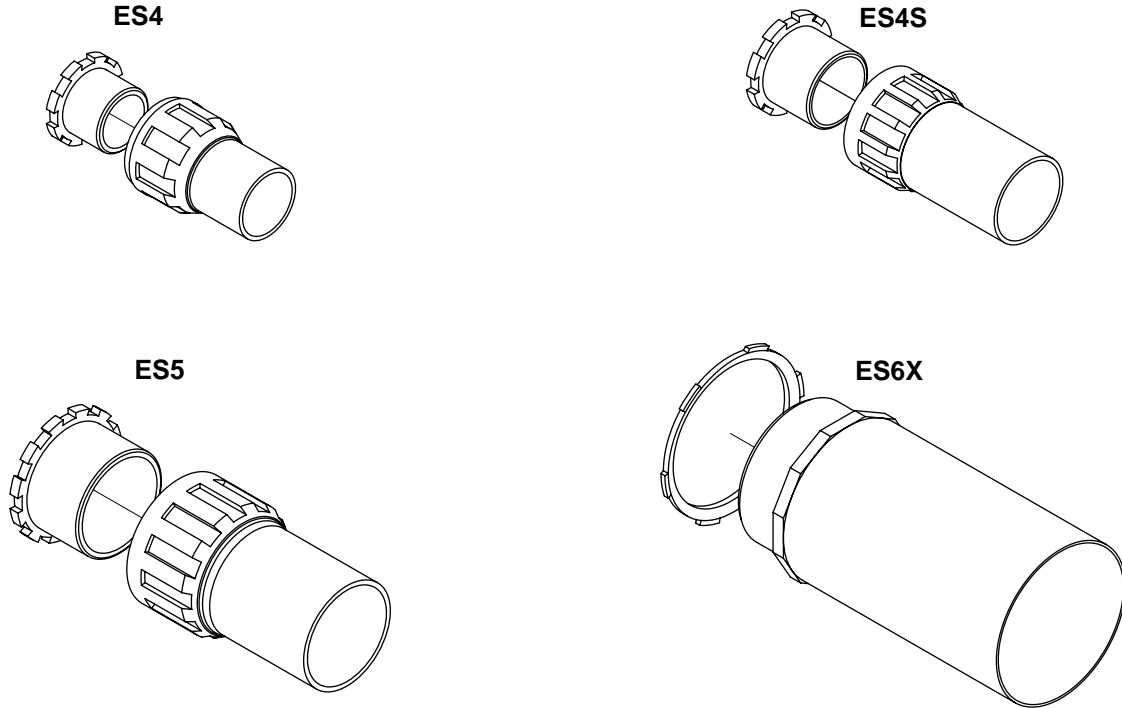

Specifications

	ES4	ES4S	ES5	ES6X
(G1) Grip Maximum	40mm (1 ⁵ / ₈ "	54mm (2 ¹ / ₈ "	70mm (2 ³ / ₄ "	90mm (3 ¹ / ₂ "
(G2) Grip Minimum	19mm (3/4"	19mm (3/4"	35mm (1 ⁷ / ₁₆ "	40mm (1 ¹ / ₂ "
(P) Maximum Panel Thickness	13mm (1/2")*	26mm (1"	26mm (1"	26mm (1"
Material	polyethylene	polyethylene	polyethylene	polyethylene
Ingress Protection	IP65	IP65	IP65	NA
(H) Mounting Hole Diameter	51mm (2"	60mm (2 ³ / ₈ "	89mm (3 ¹ / ₂ "	121mm (4 ³ / ₄ "

* Requires two stage mounting hole on 700 series enclosures.

Specifications subject to change without notice.

Worldwide Offices:

USA: 1900 Crystal Industrial Court • St. Louis, Missouri 63114 • Ph: 314/236-2020 • Fax: 314/236-2080

BELGIUM: Mallekotstraat 65 • B 2500 Lier, Belgium • Ph (+32) 3 491 9875 • Fax (+32) 3 491 9876

CANADA: Suite 400 • 609 14th Street NW • Calgary, AB T2N 2A1 • Ph 403/730-7277 • Fax 403/730-7279

obcorp@obcorp.com • www.obcorp.com